



mz Liberec

Technology for safe
and reliable healthcare



CATALOGUE

SINCE 1958





mz Liberec

Technology for safe
and reliable healthcare

- WE ARE DEVELOPING 55 YEARS' MANUFACTURE EXPERIENCE AND BRAND NAME TRADITION IN THE FIELD OF MEDICAL GAS TECHNOLOGY
- WE ARE FOCUSING OUR PRODUCTION SCOPE ON INSTALLATION OF FINAL ELEMENTS TO MEDICAL GAS DISTRIBUTION SYSTEMS, INCLUDING GAS SOURCES AND GAS PIPELINE NETWORK
- WE OFFER ALL-INCLUSIVE OPTIONS LIKE PROJECT STUDY, INTERIOR DESIGN, BUILD-UP, MANUFACTURE, FINAL ASSEMBLY ON-SITE AS WELL AS AFTER-SALE SERVICES
- WE ARE EUROPEAN MANUFACTURERS HAVING A HIGH QUALITY OF PRODUCTS, PROFESSIONAL STAFF AND TOP EXPERIENCED EXPERTS
- WE HAVE STRONG AND FLEXIBLE TEAM OF DESIGNERS-ENGINEERS WHO ARE ABLE TO PROVIDE A FULL CUSTOMIZED SOLUTION
- WE GUARANTEE RELIABLE SHIPMENTS TO ALL CUSTOMERS IN A SHORT TIME
- WE DESIGN OUR PRODUCTS UPON CUSTOMERS' WISHES AND THEIR REQUESTS ON GLOBAL APPEARANCE OF INTERIOR
- WE COMPLY INTERNATIONAL DIRECTIVES AND RULES RELATED TO MEDICAL DEVICES CONCERNED AND MEDICAL GAS DISTRIBUTION SYSTEM
- WE USE FIRST-CLASS MATERIALS AND APPLY LATEST TECHNOLOGY IN PRODUCTION PROCESSING, WHICH CONTRIBUTES TO A PROTECTION OF ENVIRONMENT
- WE PROVIDE ALL-IN-ONE ASSISTANCE TO OUR CUSTOMERS THROUGH AUTHORIZED DEALERS LOCATED ON-SITE
- WE ARE RELIABLE AND LONG-TERM PARTNERS FOR HEALTHCARE PROFESSIONALS WORLDWIDE



CONTENTS



CEILING PENDANTS

4 - 27

SWIVELLING AND TILTING CEILING PENDANTS (OK07-57, OK07-55)

6 - 9

SWIVELLING CEILING PENDANTS (OK07-28, OK07-16)

10 - 13

STATIONARY AND HEIGHT-ADJUSTABLE CEILING PENDANTS (PS07, VK07, OK07-05)

14 - 16

CEILING PENDANTS WITH COMPACT SPRING BALANCED ARMS (SPR10, SPR11)

17

SOURCE COLUMNS TO CEILING PENDANTS

18 - 25

TANDEM OPTION OF CEILING PENDANTS

26 - 27



BED HEAD UNITS AND SUPPLY COLUMN UNITS

28 - 41

BED HEAD UNITS (RN07-DN0)

30 - 31

BED HEAD UNITS (RN07-DN1)

32 - 33

BED HEAD UNITS (RN07-DN2)

34 - 35

BED HEAD UNITS (RN07-DN3, RN07-DN3Z)

36 - 39

SUPPLY COLUMN UNITS (ZS07, ZS07L)

40 - 41



MEDICAL BEAMS

42 - 45

MEDICAL BEAMS (ZMP07)

42 - 43

MEDICAL BEAMS (LAMINAR, DOUBLE-SIDED)

44 - 45



CONTENTS



MEDICAL GAS SOURCE STATIONS

46 - 49

COMPRESSOR AND VACUUM STATIONS

46 - 47

CYLINDER STATIONS

48

OXYGEN CONCENTRATORS

49



GAS DISTRIBUTION ELEMENTS

50 - 52

GAS MONITORING DEVICE (MZU 010 / II)

50

GROUP ISOLATORS

51

WALL-MOUNTED PANELS

52



AUXILIARY ELEMENTS

53 - 55

ACCESSORIES - GAS QUICK OUTLETS

53

FLOWMETERS, DISPENSERS-HUMIDIFIERS, REDUCTION VALVES

54 - 55

PROJECT ENGINEERING, ASSEMBLY, SERVICE & MAINTENANCE

56 - 57

CERTIFICATES

58 - 59

REFERENCES

60





Ceiling pendants arrange the supply of medical gases, electric power network and low voltage cabling from ceiling itself to a workplace of medical specialists. The source columns of different types (according to the specific requirements of healthcare facilities) are to be considered their integral part. The payload of ceiling pendant depends on a type of source head used and an arm length chosen. Colour and size are optional upon customer's wishes.



SWIVELLING AND TILTING CEILING PENDANTS



CEILING PENDANT TYPE →	OK07-57	OK07-55	OK07-28	OK07-16	OK07-05	PS07	VK07
horizontal setting	x	x	x	x			
single armed		x		x			
double armed	x		x				
vertical setting	x	x					x
source column A (head)	x	x	x	x	x	x	x
source column L (head)	x	x	x	x	x		
source column Z (head)			x	x	x		
rotary source column (head)	x	x	x	x	x		

OK07-57



PS07



OK07-28



 mZ Liberec

OK07-57

This type of ceiling pendant allows a variable positioning of source column either in horizontal or/and in vertical direction, and also its setting wherever within its arms might reach.





SWIVELLING AND TILTING CEILING PENDANTS

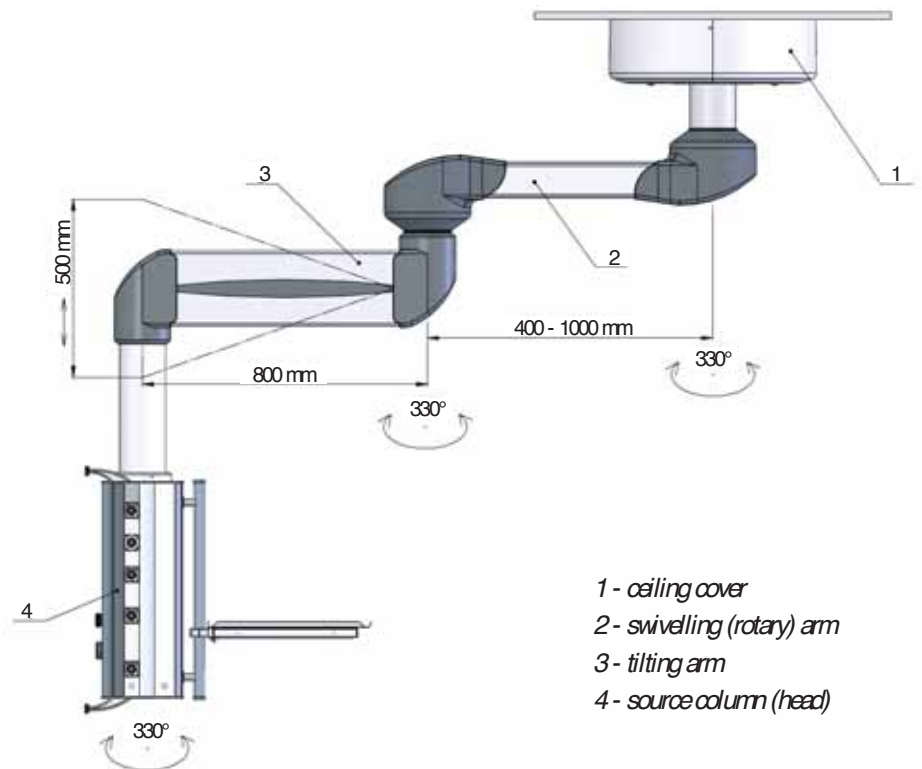

OK07-55

This type of ceiling pendant allows a variable positioning of source column either in horizontal or/and vertical direction as well as its circular motion in a certain radius determined by an arm length.

 **mz** Liberec





SWIVELLING AND TILTING CEILING PENDANTS

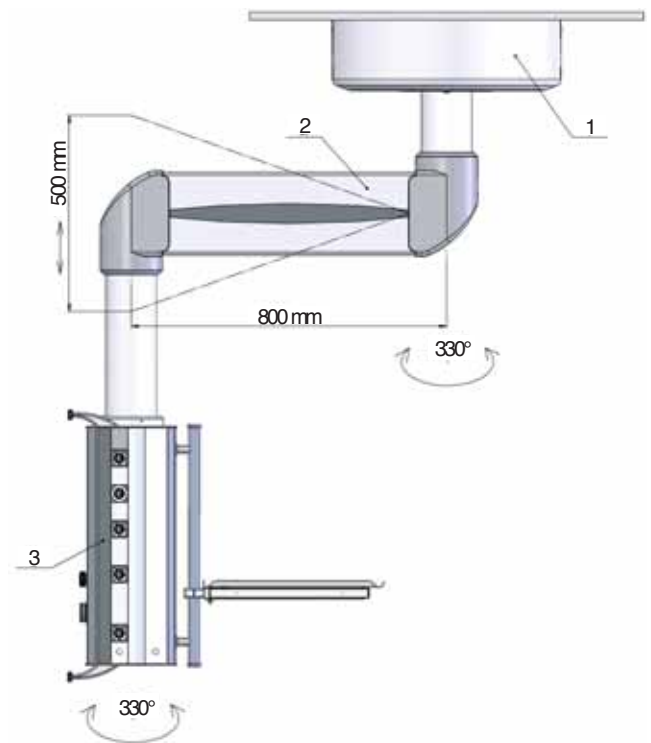

- 1 - ceiling cover
- 2 - tilting arm
- 3 - source column (head)





OK07-28

This type of ceiling pendant allows a variable positioning of source column either in horizontal or/and vertical direction as well as its setting wherever its arms might reach.





SWIVELLING CEILING PENDANTS

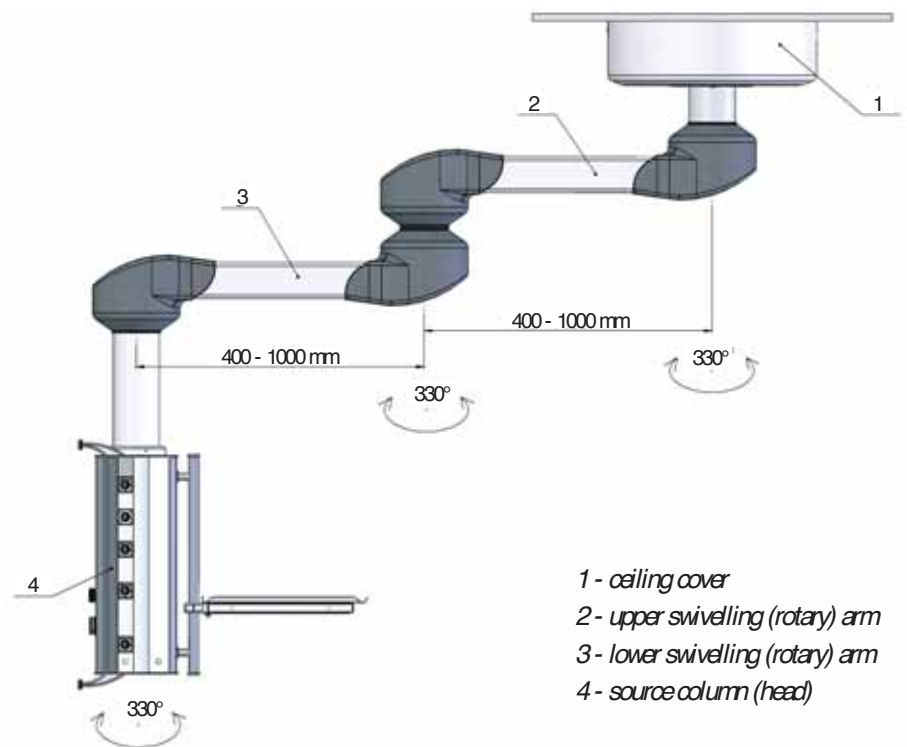

 mz Liberec

OK07-16

This type of ceiling pendant allows a variable positioning of source column either in horizontal or/and vertical direction as well as its circular motion in a certain radius determined by an arm length.





SWIVELLING CEILING PENDANTS

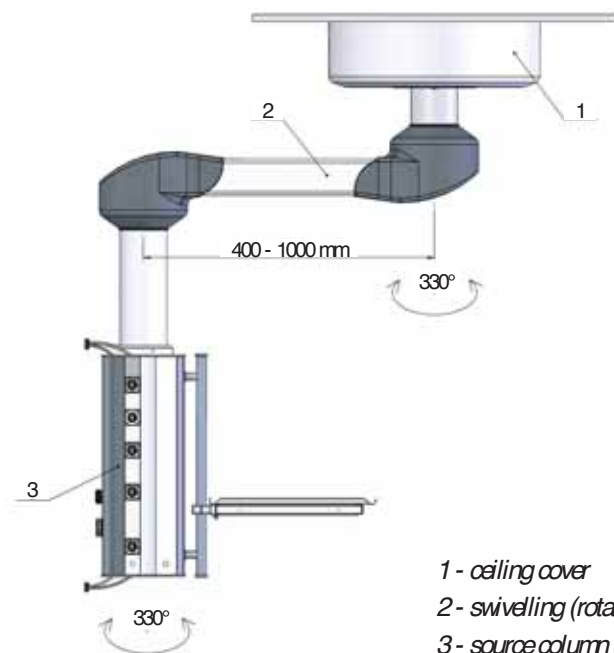

- 1 - ceiling cover
- 2 - swivelling (rotary) arm
- 3 - source column (head)





STATIONARY CEILING PENDANTS PS07



PS07



PS07 WITH SPRING BALANCED ARM SPR10

This type of ceiling pendant allows an installation of source column in a particularly specified place.

- 1 - ceiling cover
- 2 - source column (head)
- 3 - suspended shelf system

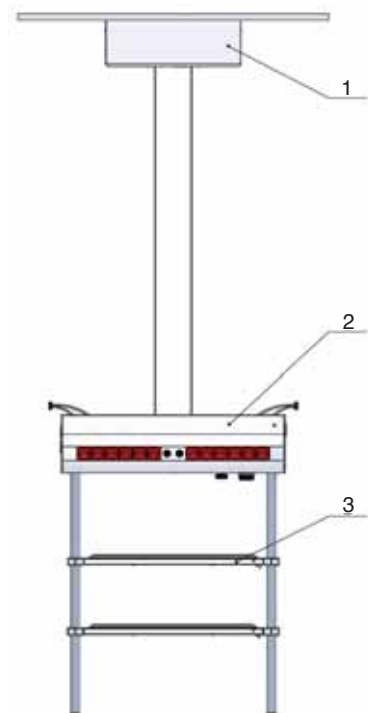



HEIGHT- ADJUSTABLE CEILING PENDANTS VK07

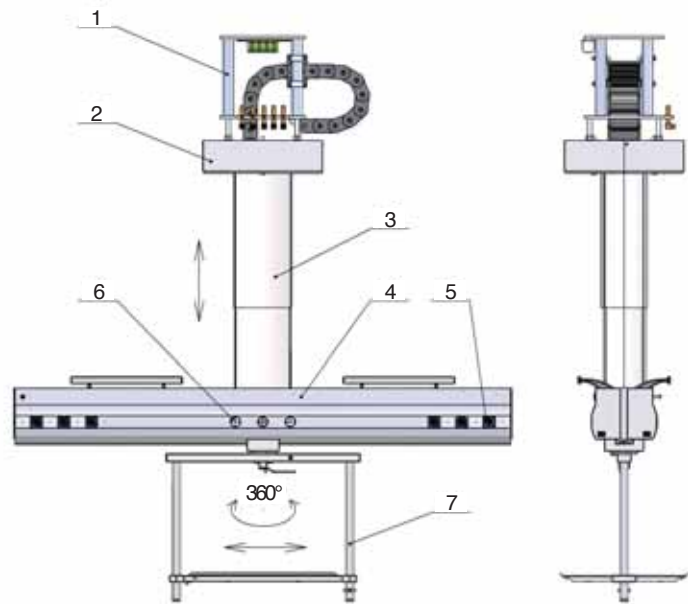

This type of ceiling pendant allows an installation of source column in a particularly specified place and its setting in a vertical position.

- 1 - fault ceiling part
- 2 - ceiling cover
- 3 - retractable stem
- 4 - source column (head)

- 5 - medical gas outlet
- 6 - inspection (control) gauges
- 7 - roller with shelves

VK07





STATIONARY CEILING PENDANTS OK07-05



OK07-05 WITH ARMS TO ANCHOR ACCESSORIES

This type of ceiling pendant allows an installation of source column in a particularly specified place and its own axis rotation.

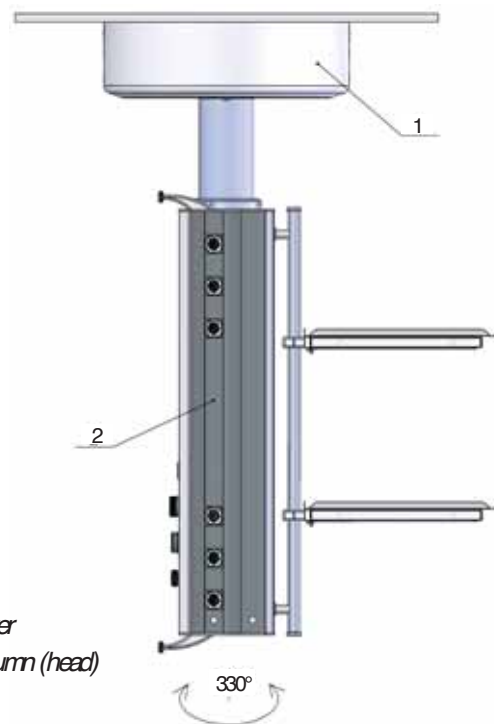

1 - ceiling cover
2 - source column (head)

330°



WITH COMPACT SPRING BALANCED ARMS SPR10, SPR11



The ceiling pendants with compact spring balanced, tilting and swivelling (rotary) arms manufactured in types SPR10 or/and SPR11 and their combinations, are carriers of medical accessories - operating lights, cameras, monitors, X-ray protective barriers and others.

Spring balanced arm with vertical unequipped tail-piece

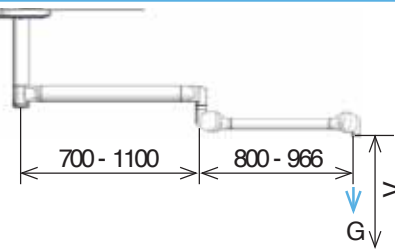

G- scope of permitted service load

5 - 28 (kg)

0 - 14 (kg)

SPR10

SPR11

1100 (mm)

950 (mm)

V - lifting height

SPR11





SOURCE COLUMNS TO CEILING PENDANTS

Such a column combines in itself medical gas outlets and electrical & media sockets in the workplace of medical staff with high demands on technical facility equipment. Its fitting is optional as per individual needs of the workplace concerned.



SOURCE COLUMNS TO CEILING PENDANTS



SOURCE COLUMNS →	L06	L10	L15	A	Z
length of rods to shelves and accessories (mm)	600	1000	1500	400 - 1000	0
recommended number of shelves	1	2	4	1	x
tread depth				x	
tread depth free	x	x	x		x
usually for anaesthetologist workplace				x	x
usually for surgeon workplace	x	x	x		
usually for surgical intervention operating theatres	x			x	



L06, L10, L15

Its front wall is equipped with two stainless steel brackets which vertically adjustable shelves, infusion pumpholders or other equipment can be attached to. The sidewalls are set with media outlets.

The source column can be combined with any arms of series CK07. Available in three lengths L06 (694 mm), L10 (1094 mm) and L15 (1594 mm) that determine the maximum equipment of the source column concerned.



SOURCE COLUMNS TO CEILING PENDANTS



- 1 - back column cover
- 2 - air motor outlet and AGSS outlet
- 3 - high-voltage electrical outlet
- 4 - jack bushes (earthing)
- 5 - arm motion control
- 6 - medical rail
- 7 - shelf
- 8 - rod for shelves and other accessories

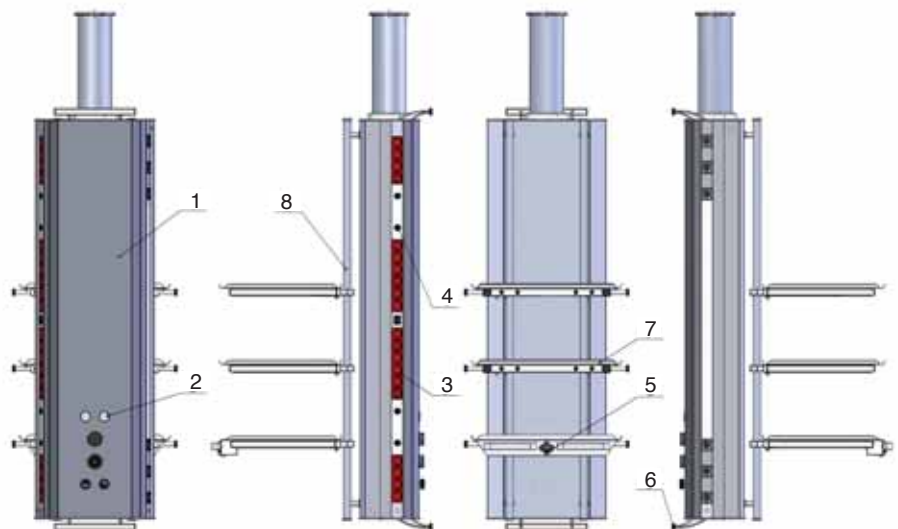

SOURCE COLUMN A (HEAD)

This source column is the most frequently used either in anaesthesiology section or wherever it is necessary to have enough space hereunder. Column setting is optional as per the individual needs of the workplace. In the bottom part this source column may be equipped with two stainless steel brackets which vertically adjustable shelves, infusion pump holders or other equipment can be fitted to. The front and rear walls are set with media outlets. The source column can be combined with any arms of series CK07.





SOURCE COLUMNS TO CEILING PENDANTS



- 1 - medical gas quick outlets
- 2 - air motor outlet and AGSS outlet
- 3 - high-voltage electric sockets
- 4 - jack bushes (earthing)
- 5 - arm motion control
- 6 - medical rail
- 7 - shelf
- 8 - rod for shelves and other accessories

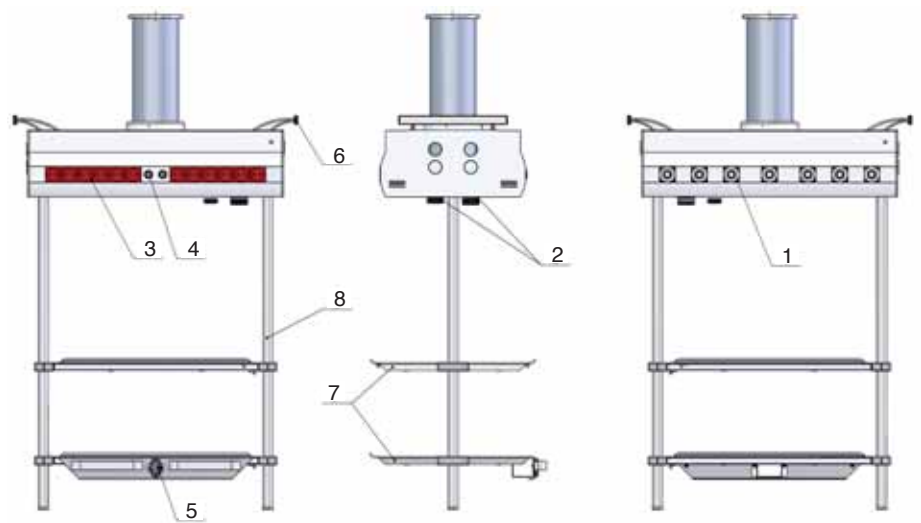

SOURCE COLUMN Z

This source column is the most frequently used in anaesthesiology section. Its advantage is possibility to suspend an anaesthesiologic machine on. This feature allows a permanent connection between that device and the source column when handled in the operation theatre and when this area is disinfected. Column fitting is optional as per individual needs of the workplace concerned. The source column can be fitted with different standard holders of anaesthesiologic device. Media outlets are set from the rearwall of the column. The source column can be combined with arms of series CK07-28, CK07-16, CK07-05.





SOURCE COLUMNS TO CEILING PENDANTS



- 1 - medical gas quick outlets
- 2 - gauges
- 3 - high-voltage electric sockets
- 4 - jack bushes (earthing)
- 5 - lift control of machine holder
- 6 - arm motion control
- 7 - holder of anesthesiology machine
- 8 - handle with control button
- 9 - air motor outlet and AGSS outlet

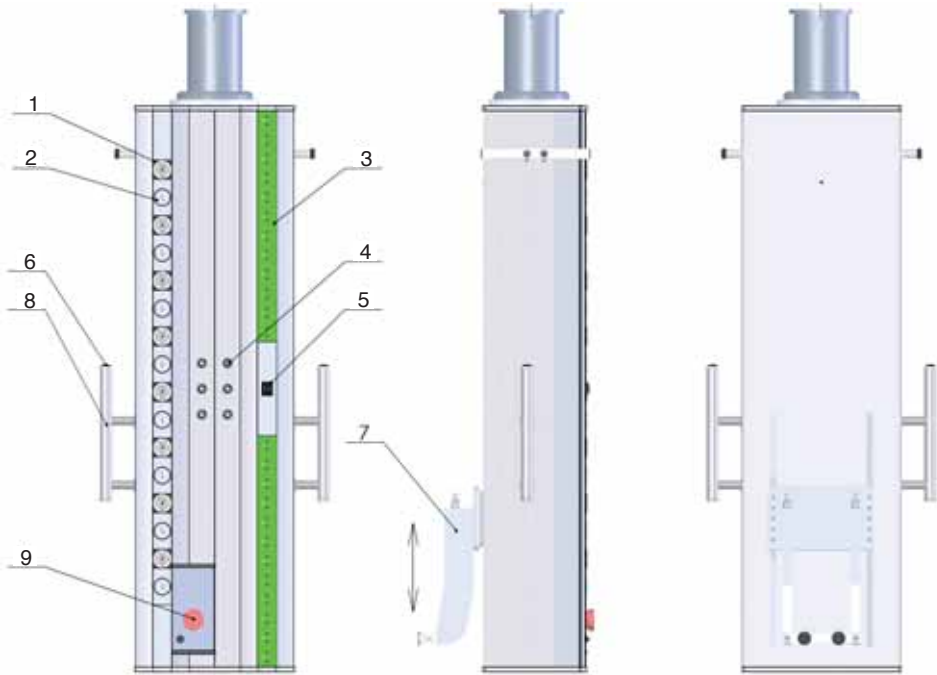

Any type of ceiling pendant and source columns can be combined each other, altogether. This option is suitable for healthcare facilities with the most intensive patient care. Its main advantage is the high capacity of media outlets and possibility to mount a large number of different accessories and equipments. Of course, it is comfortable for physicians and nurses as well.





TANDEM OPTION OF CEILING PENDANTS

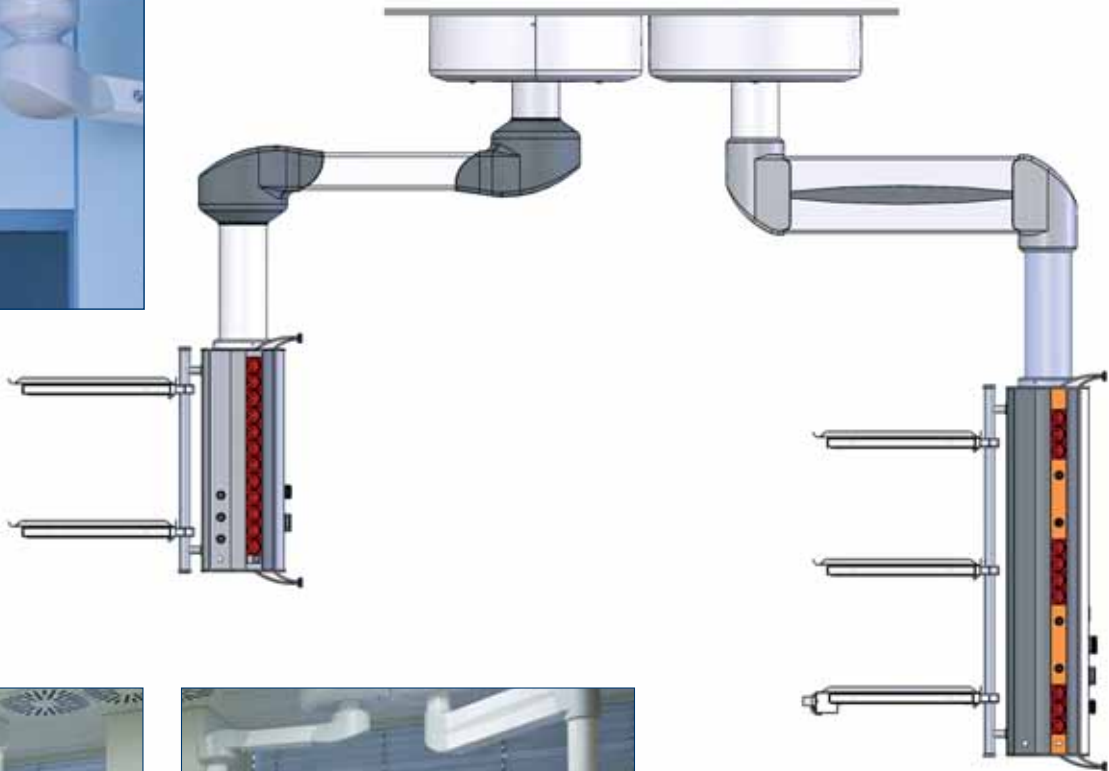
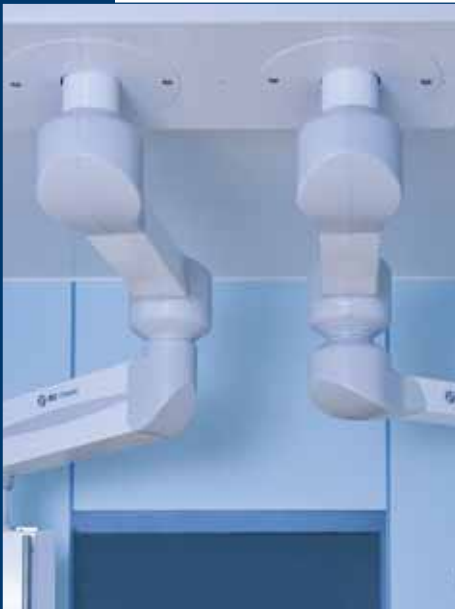

Bed head units are especially designed for patients' wards and medical facilities, where medical gas outlets, high-voltage and low-voltage sockets are required. Direct, indirect or night lights (either fluorescent or LED types) may become a part of bed head units, too. Their design is often matching the total appearance of ward interior.



BED HEAD UNITS

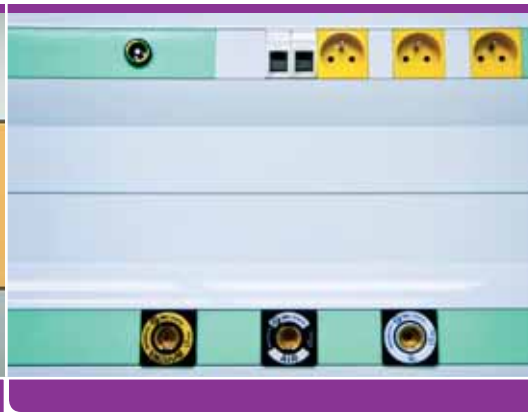
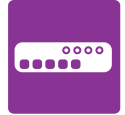

BED HEAD UNIT TYPE →	DN0	DN1	DN2	DN3	DN3-Z	ZS07
horizontal installation	x	x	x	x	x	
vertical installation						x
direct and night lighting	x	x	x			
indirect lighting	x	x	x			x
fitting to medical gases		x	x	x	x	x
for in-patient wards	x	x	x		x	
for ICU			x	x	x	x
wall built-in					x	
multiple-bed options	x	x	x	x		





RN07-DN0

Bed head unit RN07-DN0 is designed for standard patient wards where no medical gas outlets are needed. It contains high-voltage and low-voltage power installations. It can be fitted direct, indirect and night lighting. Of course, medical rail and other optional accessories can be mounted on.



BED HEAD UNITS

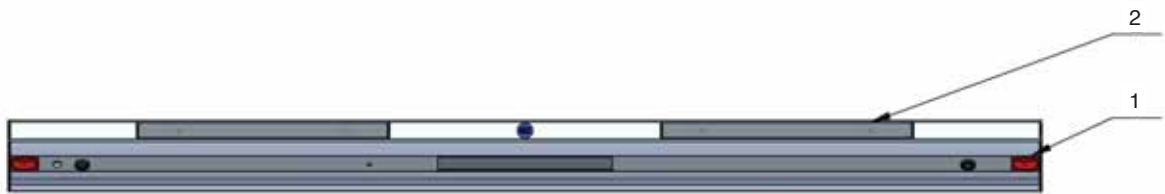
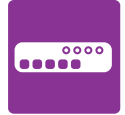

1 - high-voltage electric sockets
2 - medical rail

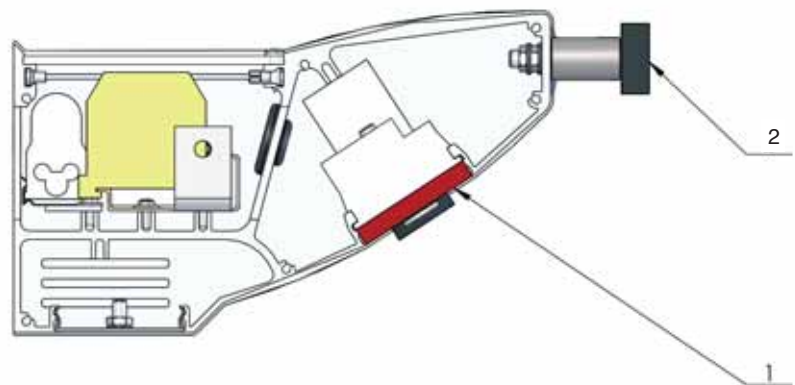

RN07-DN1

Bed head unit RN07-DN1 is designed for standard patient wards where medical gas outlets, high-voltage & low-voltage installations are needed. It can be equipped with direct, indirect and night lights. Of course, medical rail and other optional accessories can be mounted on.

BED HEAD UNITS

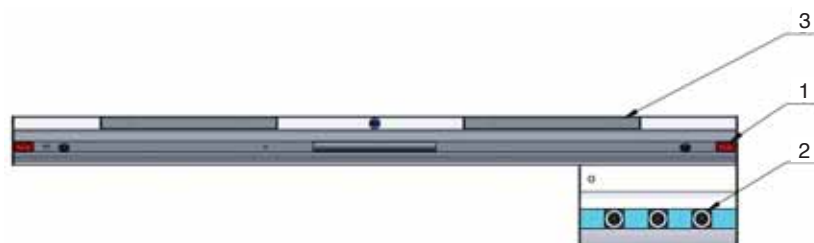
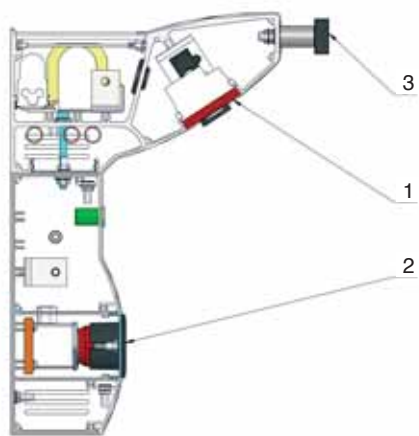

- 1 - high-voltage electric sockets
- 2 - medical gas quick outlets
- 3 - medical rail



RN07-DN2

Bed head unit RN07-DN2 allows a multi-spectral placement of medical gas outlets and low-voltage installations on the left/right side or just in the middle of itself. It is distinguished by an easy plugging-in of multibedded options to the medical gas distribution system and low-voltage power circuit.



BED HEAD UNITS

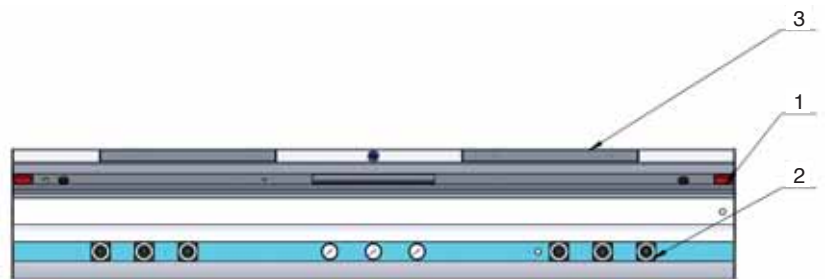
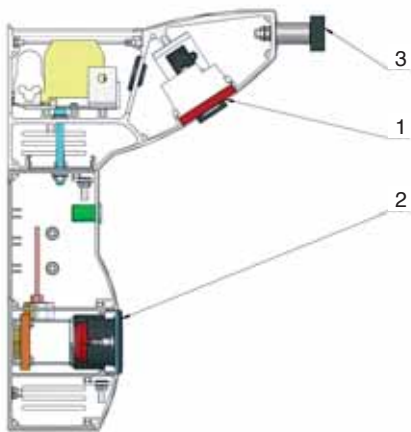
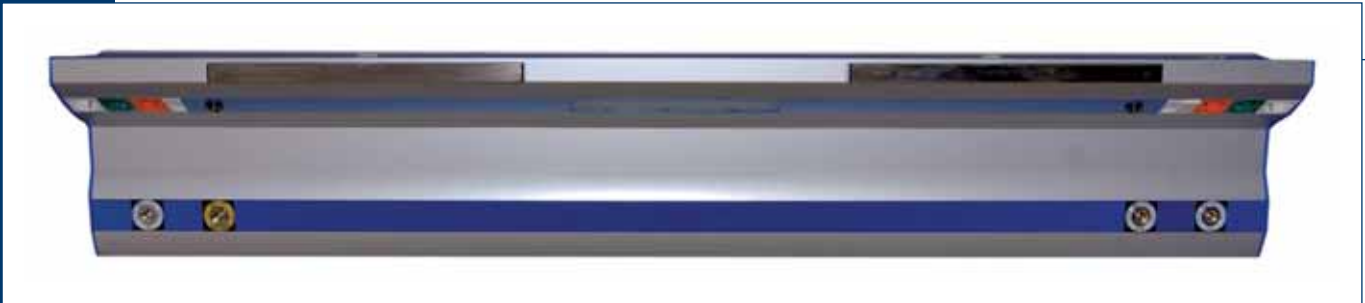
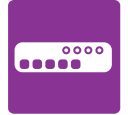

- 1 - high-voltage electric sockets
- 2 - medical gas quick outlets
- 3 - medical rail





RN07-DN3

Bed head unit RN07-DN3 allows a multi-spectral placement of medical gas outlets and low-voltage installations on the left/right side or just in the middle of itself. It is distinguished by an easy plugging-in of multibedded options to the medical gas distribution system and low-voltage power circuit. Its essential advantage is a low depth. So it does not touch the manipulation space in front of itself.

BED HEAD UNITS

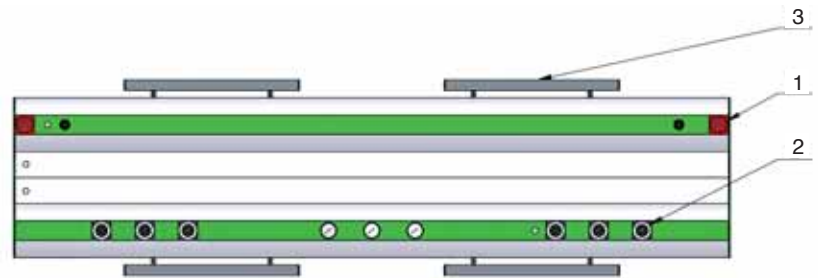
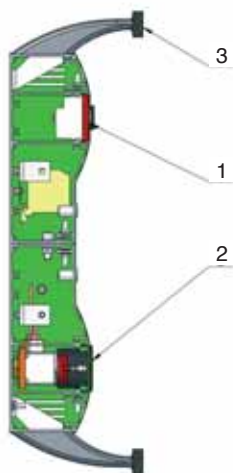
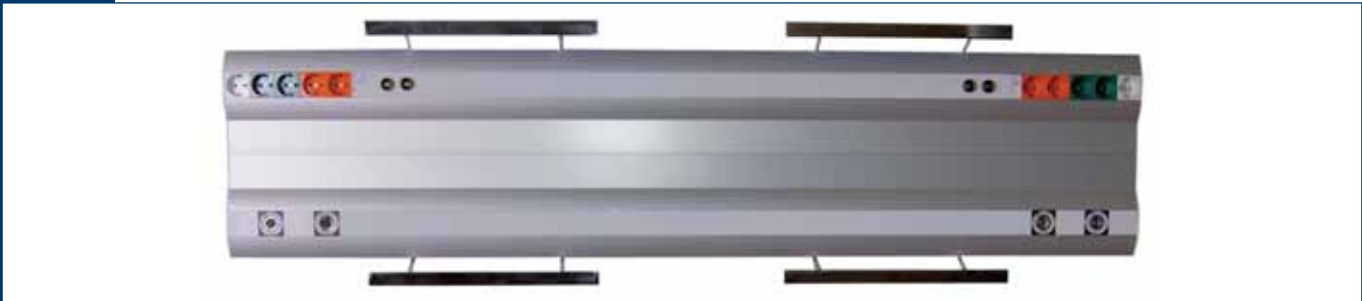
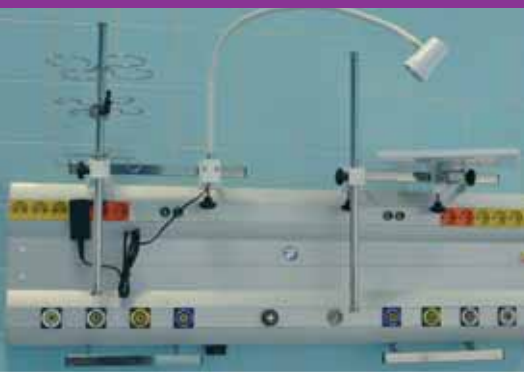
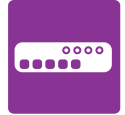

- 1 - high-voltage electric sockets
- 2 - medical gas quick outlets
- 3 - medical rail



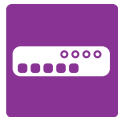

SINGLE-CHANNELLED RN07-DN3



RN07-DN3

Bed head unit RN07-DN3 is designed for standard patient wards with a need of medical gas outlets. It contains high-voltage and low-voltage installations. Medical rail and other optional accessories can be mounted on. Its essential advantage is a low depth. So it does not touch the manipulation space in front of itself.

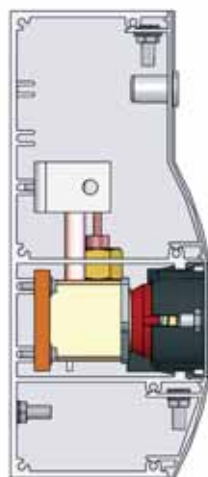
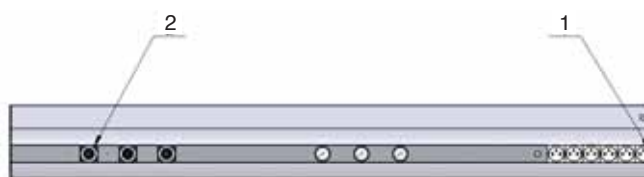

- 1 - high-voltage electric sockets
- 2 - medical gas quick outlets



IN-BUILT RN07-DN3Z

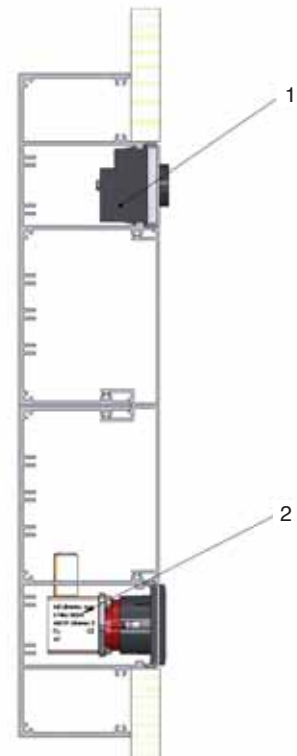

This bed head unit is designed for standard in-patient wards with the need for outlets of medical gases, high-voltage electricity and low-voltage installations. Optional accessories can be mounted on bed head unit, too. Its main feature is the design intended for installation in the interior (part of a furniture set, behind a painting, etc.)

- 1 - high-voltage electric sockets
- 2 - medical gas quick outlets

RN07-DN3Z



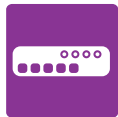

SUPPLY COLUMNS ZS07



ZS07

Supply columns are mainly used in places where it is impossible to install bed head unit, i.e. between windows, glazed walls, support columns, etc. The rod mounted on the column fore-side is intended for fixation of adjustable rotar shelves with medical rails and accessories.

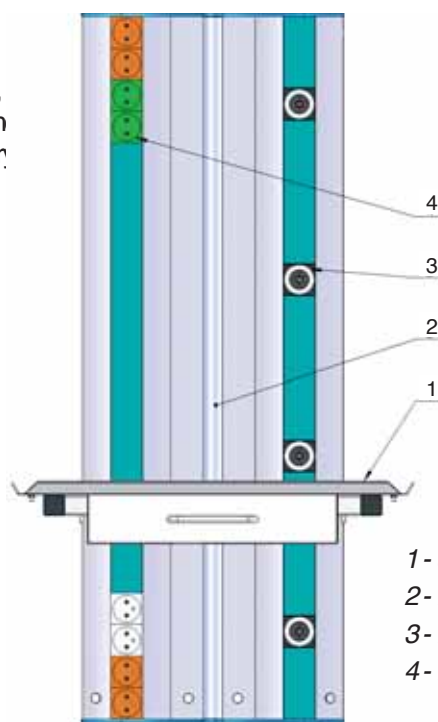

- 1 - shelf
- 2 - rod for shelves and other accessories
- 3 - medical gas quick outlets
- 4 - high-voltage electric sockets



SUPPLY COLUMNS ZS07L

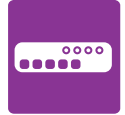

These vertical supply columns are primarily fitted in such a space where bed head units cannot be wall-mounted, i.e. between windows, on glass-walled areas, on supporting pillars etc.. In the front side of supply column there is a rod used for fixation of height-adjustable and adaptive shelves equipped with medical rails and accessories.

- 1 - shelf
- 2 - rod for shelves and other accessories
- 3 - medical gas quick outlets
- 4 - high-voltage electric sockets
- 5,6 - indirect lighting

ZS07L

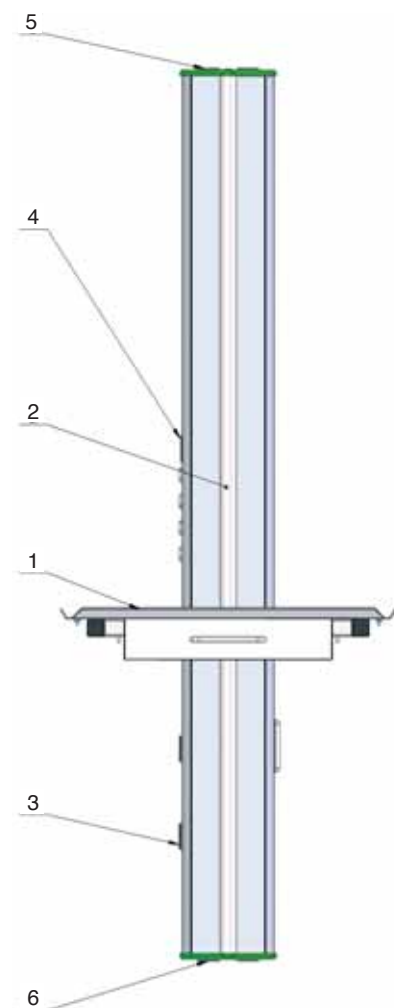

ZMP07

Medical beams are designed to provide medical gas, electric power and data distribution as close as possible to the bedside area. It is mainly used for specialized medical facilities (ICU, ARD). The medical beam can be fitted with halogen or LED spot lamp, bracket arms, telescopic rod with curtain, medical rail, positional (night) light or other accessories upon needs & requirements of the workplace concerned. Thanks to its design it ensures an optimal use of space with regard to safety of patient as well as medical staff.



MEDICAL BEAM

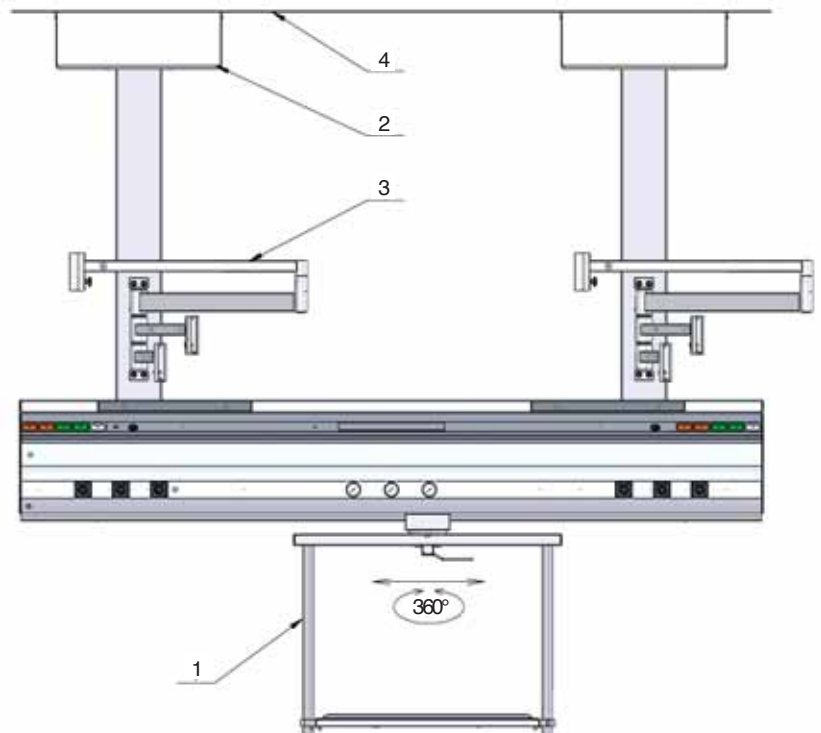

- 1 - rotary roller with shelf
- 2 - ceiling cover
- 3 - arms for accessories
- 4 - suspended ceiling depth





LAMINAR ZMP07



ZMP07

Laminar medical beam ZMP07 is used wherever a laminar air-flow coming from ceiling to be streamlined, namely in supra-aseptic environment. It is available in U- or L-shaped options, too.

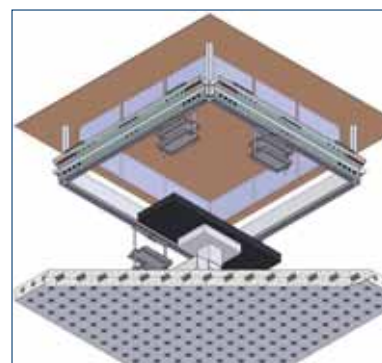



DOUBLE-SIDED ZMP07



This type of medical beam is used wherever medical gas outlets and high/low-voltage installations to be fitted both module sides.

- 1 - electrical socket
- 2 - indirect light
- 3 - direct light
- 4 - medical rail
- 5 - gas quick outlet
- 6 - beam stem

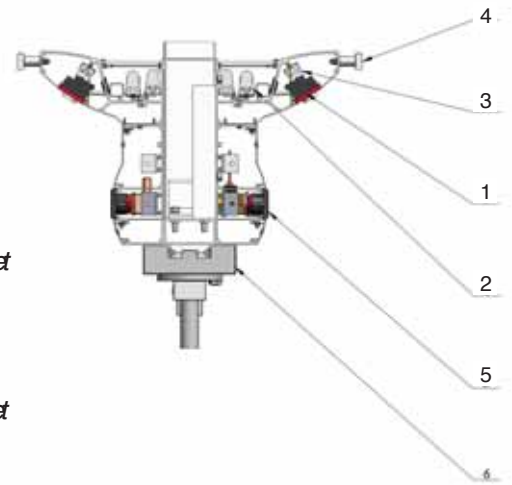

ZMP07

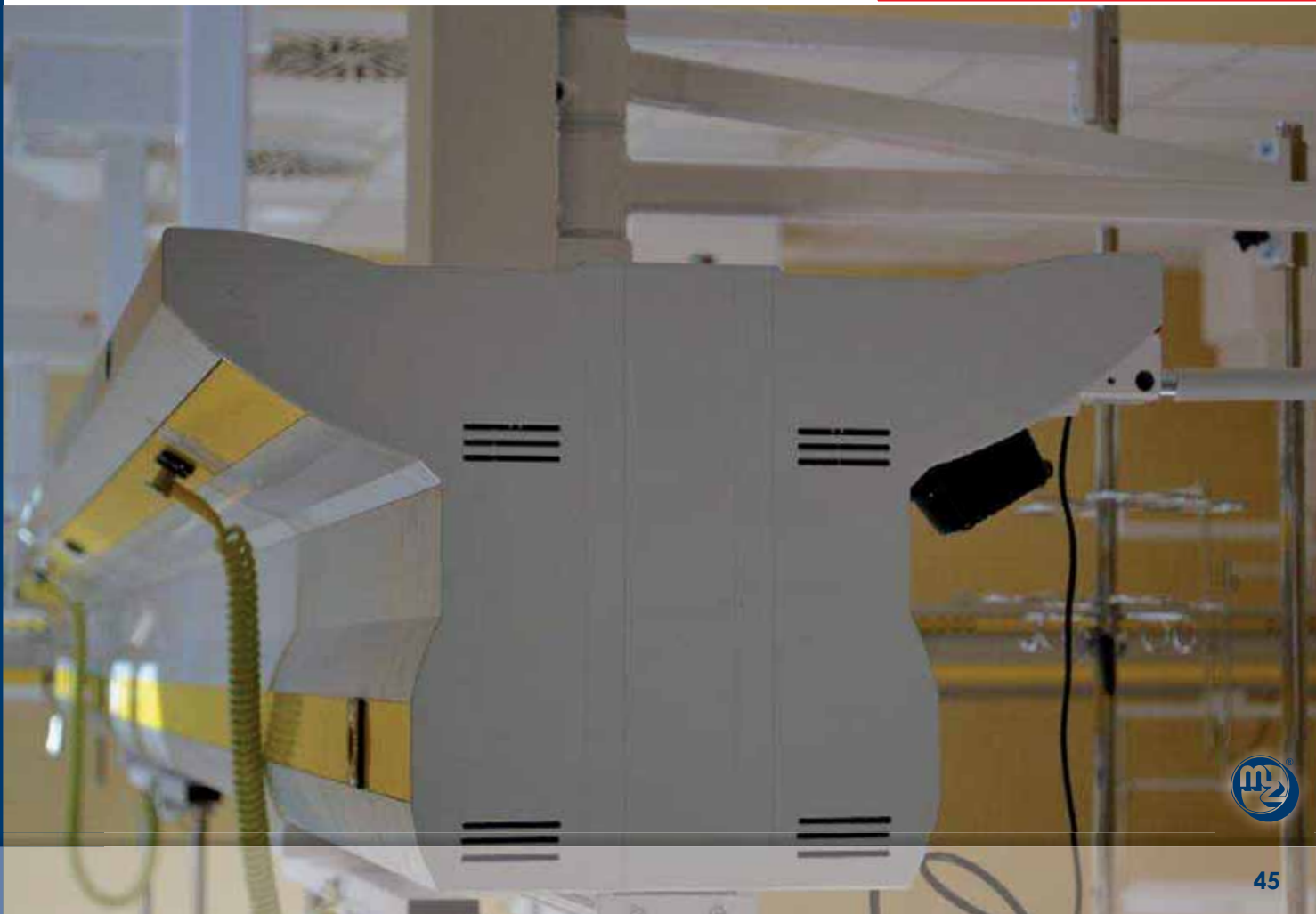



COMPRESSOR STATIONS



Compressor station provides (in automatic mode) the required pressure and the planned flow of medical compressed air, in a quality complied with European Directives as well as other standards valid worldwide. They are stationary units available in several options, e.g. oilfree - oil, spiral - piston, differing each other by cooling substance, type of drive, etc. Standard compressor stations are supplied with an output of 2.2 to 608 Nm³/hour.





VACUUM STATIONS



It provides (in automatic mode) the required suction and the planned flow of medical vacuum for needs of vacuum suction. A very important part is treatment and cleaning of contained exhaust air. Therefore, it is necessary to equip each vacuum station in automatic mode with perfect antibacterial filter and dirt arrester.

Standard range of vacuum stations with capacities from 6.4 to 632 Nm³/hour is supplied.





CYLINDER STATIONS



Cylinder solution is the oldest, the most proven and also the cheapest investment method how to arrange the medical gas supply. However its great disadvantage consists in a difficult handling with heavy cylinders and in a costly maintenance. We supply cylinder sources with automatic, semi-automatic and manual switches. The designed flow is 15 m³/hr to 300 m³/hr.





OXYGEN CONCENTRATORS



Complete OXYSWING® System.

Air Compressor
Refrigerated Dryer
Air Buffer Tank
PSA Concentrator
Oxygen Receiver
Sterile Filters

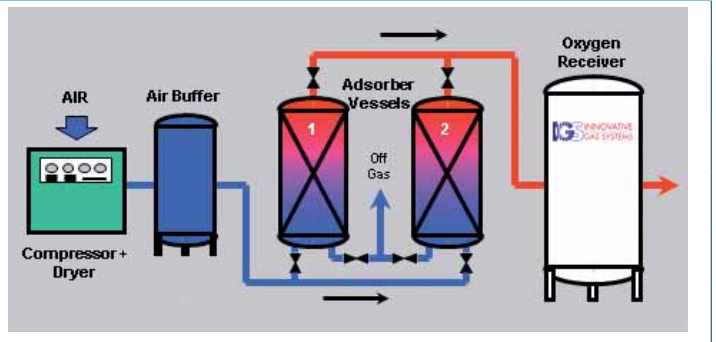

Oxygen concentrator is based on the use of molecular sieves being able to separate nitrogen from oxygen because of different size of molecules. This equipment is able to produce oxygen-enriched air with 93-95% oxygen. This gas may replace medical oxygen in case all required features are observed. Oxygen concentrator is available in six different volumes with a production capacity from 3 to 48 Nm³/hr O₂.





GAS PRESSURE WARNING MZU 010 / II



MZU 010 / II

Monitoring device MZU with touchscreen is designed for clinical and operational status warning in medical gas pipeline and distribution resources. Its purpose is either to warn the staff by means of light or/and sound alarm that something unusual with gas pressure, flow or supply happened, or to send a status information to external devices. MZU can be built-in or wall-mounted, its setting is always done in menu using a touchscreen. The pre-setting of the monitored parameters is done in device menu through touchscreen directly at the place of installation

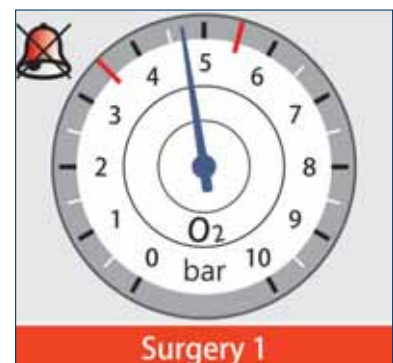



GROUP ISOLATORS

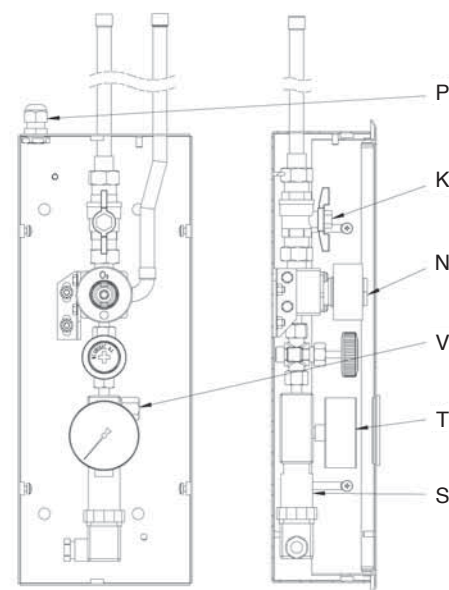

Group isolator is intended for stopping the gas flow to the next distribution area. It serves solely for emergency purposes and for maintenance, not for routine use. Its pressure sensors are designed for warning because of non-standard pressure in the distribution area concerned. They are configured for upto 5 gases, including any combination of your own choice.

- K- branch closing (*ball cocks with selected parameters)*
- V- drains*
- N- emergency inputs: DN4, PN 10 medical gas quick outlets*
- T- output pressure gauges **
- S- pressure sensors* (for signalling systems)*
- P- signalling wire passage*

SU 03





WALL-MOUNTED PANELS



UR.17 B

Wall-mounted panels is connecting point to the medical gas distribution network. It can be equipped either with a medical gas quick outlet specified for gas concerned or with a pressure gauge. They are manufactured in two options - either with surgical instruments drive - air engine or with exhaust system adapted to exhale mixtures of anaesthetic gases - AGSS. It can be built-in or wall-mounted.





GAS QUICK OUTLETS



Gas quick outlet is intended for easy connection and disconnection of two distribution sections. When connected with the counter-piece in question, the tough and tight circuit is created. In case of disconnection it works like a self-acting stopper with separation valve. The gas quick outlet is available in several options that differ each other with a kind of mounting on mother board and way of connection to the central distribution network. It is immutable for certain gases and manufactured in colour-distinguishable media options. The adaptors are placed into the gas quick outlets and such a connection becomes a functional unit.

Type denomination	Gas	Colour
UR 107	O ₂	white
UR 507	N ₂ O	blue
UR 607	air	black & white
UR 807	negative pressure	yellow & black
UR 707	CO ₂	grey





FLOWMETERS DISPENSERS-HUMIDIFIERS



FLOWMETER ME.03



DISPENSER - HUMIDIFIERS MZ 103 F, MZ 104 F

They are intended for oxygen dosage from central distribution network and simultaneously for its efficacious humidification. The relative oxygen humidity is 80 pct at least. They can be easily linked up to other oxygen distribution sealings with gas quick outlets. Their flow can be adjusted in two levels - 1 to 5 l/min and/or 2 to 20l/min.





VACUUM REDUCTION VALVE



RV.02 is a special low-pressure reduction valve intended for manual pressure adjustment of passing-through fluid media. Its connectable to all (formerly or temporarily) manufactured gas quick outlets. Input pressure is 300 - 1000 kPa, output pressure is 20 - 700 kPa.

Vacuum reduction valve type VR.01 is intended for a reduction of underpressure coming from central distribution underpressure circuit. It is connectable to all underpressure distribution sealings with gas quick outlets. The underpressure adjustment is achieved by turning the regulation knob located in the valve body axis. It is equipped with a vacuum meter that may check the output underpressure in a range from 0 up to 100 kPa.

RV.02

VR.01



PROJECT ENGINEERING

The company is fully certified for all its project engineering activities. The team of designers is ready to give a turn-key project solution, i.e. gas sources, pipeline distribution network and source column supply units of medical as well as technical gases included. Any project engineering services are provided in a full compliance with EN 7396 or local norms (if requested). We are able to satisfy any customers, starting from small projects through huge hospital deals. The top-class project study is always tailor-made and trying to meet all client's possible and/or impossible dreams.

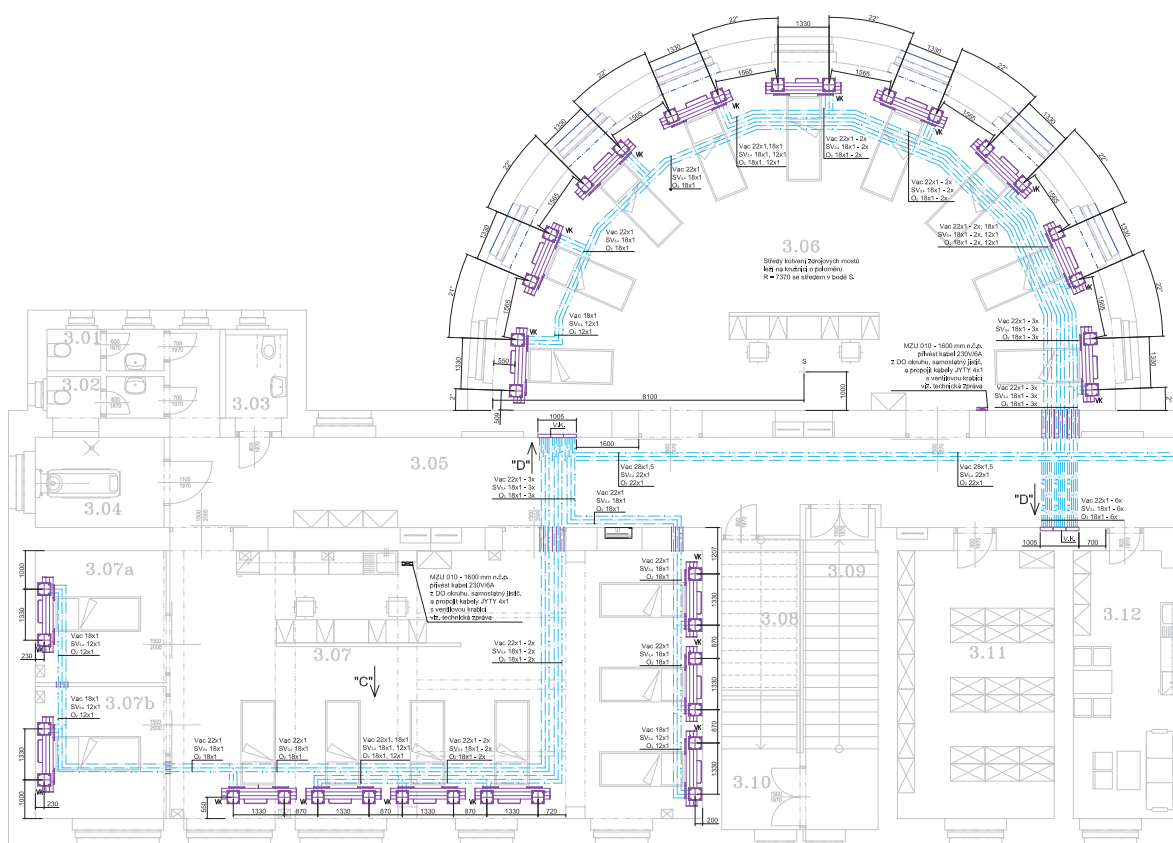

ASSEMBLY

Our experienced and permanently well-trained staff provides a high-quality assembly of the supplied medical gas devices on-site, both in the Czech republic and in abroad. These assembly services are done in a conformity to EN 7396. The assembly period is tailored to the customers' requests and notions.



SERVICE AND MAINTENANCE

We offer a wide range of services that may seriously reduce the standard user's risks. Such services are provided within a guarantee period or/and thereafter, general overhauls included. Furthermore the safety and functionality testing (like regular safety technical controls), check-ups, inspections, drawing-ups of operational documents, status reports (including rectification proposals) are realized as well.

On the territory of the Czech republic we are entitled to provide and to offer quality check-ups of medical gases as per European Pharmacopoeia. Our laboratory has been appointed for that business by the State Institute of Drug Control in Prague.





CERTIFICATE

IQNet and CQS hereby certify that the organization

MZ Liberec, a.s.
U Nisy 362/6, 460 01 Liberec 3, Czech Republic
Premise Rudník

- for the following processes
- Projecting, purchasing, developing, sale, mounting and service, incl. testing of operating personnel and management
 - medical and laboratory technique
 - medical gases distribution nets and AGSS systems, in accordance with ČSN EN 737, and their components and subsystems, incl. sources and medical source units in accordance with ČSN EN ISO 11197
 - technical gases distribution nets and their components and subsystems
 - distribution nets of other gases, which are operated analogous to medical gases and their components and subsystems
 - distribution nets components, determined for their gripping (anchoring sets, cones, etc.)
 - items, attachable to outputs of gas distribution systems (gas outlets counterparts, gas dispensers, humidifiers of oxygen, ejector suction bottles, pressure and vacuum regulators, etc.)
 - additional accessories to the medical source units and medical and technical gases distribution nets (inflation pumps and sets holders, hangers, cones, suspension arms, rods, medical rails, shelves)
 - reducing valves, attachable to cylinders and their accessories

has implemented and maintains a
Quality Management System
which fulfills the requirements of the following standard

ISO 9001 : 2008

Issued on: 2010 - 06 - 24
Validity date: 2013 - 08 - 24

Registration Number: **CZ - 2242/2010**



René Wimmer
René Wimmer
President of IQNet

Vladimír Filáš
Vladimír Filáš
President of CQS



IQNet Partners*
AENOR Spain AFNOR Certification France AIB-Vioprofit International Belgium ANCE Mexico APCER Portugal CIBQ Italy CQC China CQM China CQS Czech Republic Csa Certi Cesnate DQS Holding GmbH Germany DS Denmark ELDT Greece JAV Brazil IONOR/IONEMA Venezuela IRGASA Hong Kong China IQNET Colombia IMC Mexico Inogen Certification Finland IRAM Argentina JQA Japan KQF Korea MIST Hungary Nemo AS Norway NSAI Ireland PCBC Poland Quality Austria Austria RR Russia RS Russia RQ Slovenia RSBM QAS International Malaysia SQS Switzerland SMAC Romania TEST in Plevning Russia THE Turkey TSOB Serbia
IQNet is represented in the USA by: AFNOR Certification, CQS, DQS Holding GmbH and NSAI Inc.
The list of IQNet partners is valid at the time of issue of this certificate. Updated information is available under www.iqnet-certification.com



CERTIFICATE

IQNet and CQS hereby certify that the organization

MZ Liberec, a.s.
U Nisy 362/6, 460 01 Liberec 3, Czech Republic
Premise Rudník

- for the following processes
- Projecting, purchasing, developing, sale, mounting and service, incl. testing of operating personnel and management
 - medical and laboratory technique
 - medical gases distribution nets and AGSS systems, in accordance with ČSN EN 737, and their components and subsystems, incl. sources and medical source units in accordance with ČSN EN ISO 11197
 - technical gases distribution nets and their components and subsystems
 - distribution nets of other gases, which are operated analogous to medical gases and their components and subsystems
 - distribution nets components, determined for their gripping (anchoring sets, cones, etc.)
 - items, attachable to outputs of gas distribution systems (gas outlets counterparts, gas dispensers, humidifiers of oxygen, ejector suction bottles, pressure and vacuum regulators, etc.)
 - additional accessories to the medical source units and medical and technical gases distribution nets (inflation pumps and sets holders, hangers, cones, suspension arms, rods, medical rails, shelves)
 - reducing valves, attachable to cylinders and their accessories

has implemented and maintains a
Quality Management System
which fulfills the requirements of the following standard

ISO 13 485 : 2003

Issued on: 2010 - 06 - 24
Validity date: 2013 - 08 - 24

Registration Number: **CZ - 174/2010**



René Wimmer
René Wimmer
President of IQNet

Vladimír Filáš
Vladimír Filáš
President of CQS



IQNet Partners*
AENOR Spain AFNOR Certification France AIB-Vioprofit International Belgium ANCE Mexico APCER Portugal CIBQ Italy CQC China CQM China CQS Czech Republic Csa Certi Cesnate DQS Holding GmbH Germany DS Denmark ELDT Greece JAV Brazil IONOR/IONEMA Venezuela IRGASA Hong Kong China IQNET Colombia IMC Mexico Inogen Certification Finland IRAM Argentina JQA Japan KQF Korea MIST Hungary Nemo AS Norway NSAI Ireland PCBC Poland Quality Austria Austria RR Russia RS Russia RQ Slovenia RSBM QAS International Malaysia SQS Switzerland SMAC Romania TEST in Plevning Russia THE Turkey TSOB Serbia
IQNet is represented in the USA by: AFNOR Certification, CQS, DQS Holding GmbH and NSAI Inc.
The list of IQNet partners is valid at the time of issue of this certificate. Updated information is available under www.iqnet-certification.com

CQS - Czech Association for Quality Certification
Pod Lisem 129, 171 02 Praha 8 - Troja
Czech Republic

CQS is the Certification Body accredited according to Standard EN ISO/IEC 17021:2007 by the Czech Institute for Accreditation under the registration No. 3029 for the Certification of Quality Management Systems



CERTIFICATE

No.: **CQS 174/2010**

CQS - Czech Association for Quality Certification - certifies that the Quality Management System of

MZ Liberec, a.s.
U Nisy 362/6, 460 01 Liberec 3, Czech Republic
Premise Rudník

has been assessed and found to be in conformity with the requirements of

EN ISO 13485 : 2003

with respect to the following scope. Technical areas are presented in the audit report dated 23.06.2012
Project planning, purchase, development, production, sale, installation and service of non-active and active medical devices:

- medical and laboratory equipment
- medical gas central distribution and AGSS systems according to the standard ČSN EN 737 and their components, incl. medical supply units according to ČSN EN ISO 11197 and gas sources
- distributions of technical gases and their components
- elements for connecting into outputs of distribution systems (counterparts of quick couplings, dosing meters of gas, oxygen humidifiers)
- ejector vacuum pumps, regulators of pressure and vacuum etc.
- additional equipment to medical supply units and to distributions of medical gases for example holders of inflation pumps and inflation sets, hangers, medical sets, hanging arms, suspension rods, shelves, armature sets etc.
- reduction valves determined for the direct connection to pressure bottles

The certificate is valid until: 24. 08. 2013
Certification decision: 24. 08. 2010
Date of issue: 24. 08. 2010
Date of change: 23. 08. 2012
Date of granting the first certificate: 10. 06. 2004



Jana Orlánská
Jana Orlánská
Managing Director



CQS Members*
Elektrotechnický studijní ústav, s.p., Průmyslný technický studijní ústav, s.p., Institut pro testování a certifikaci, s.p., Strojnický studijní ústav, s.p., Technický a studijní ústav stavění Praha, s.p., Technický a studijní ústav stavění Praha, s.p., - střední ústav - ZÚP, Technický studijní ústav, s.p.
* A CQS member list valid at the time of issue of the certificate. Current list is available at www.cqs.cz

CQS - Czech Association for Quality Certification
Pod Lisem 129, 171 02 Praha 8 - Troja
Czech Republic

CQS is the Certification Body accredited according to Standard EN ISO/IEC 17021:2006 by the Czech Institute for Accreditation under the registration No. 3029 for the Certification of Quality Systems



CERTIFICATE

No.: **CQS 2242/2010**

CQS - Czech Association for Quality Certification - certifies that the Quality Management System of

MZ Liberec, a.s.
U Nisy 362/6, 460 01 Liberec 3, Czech Republic
Premise Rudník

has been assessed and found to be in conformity with the requirements of

EN ISO 9001 : 2008

with respect to the following processes:

- Projecting, purchasing, developing, sale, mounting and service, incl. testing of operating personnel and management
- medical and laboratory technique
- medical gases distribution nets and AGSS systems, in accordance with ČSN EN 737, and their components and subsystems, incl. sources and medical source units in accordance with ČSN EN ISO 11197
- technical gases distribution nets and their components and subsystems
- distribution nets of other gases, which are operated analogous to medical gases and their components and subsystems
- distribution nets components, determined for their gripping (anchoring sets, cones, etc.)
- items, attachable to outputs of gas distribution systems (gas outlets counterparts, gas dispensers, humidifiers of oxygen, ejector suction bottles, pressure and vacuum regulators, etc.)
- additional accessories to the medical source units and medical and technical gases distribution nets (inflation pumps and sets holders, hangers, cones, suspension arms, rods, medical rails, shelves)
- reducing valves, attachable to cylinders and their accessories

The certificate is valid until: 24. 08. 2013
Certification decision: 24. 08. 2010
Date of issue: 24. 08. 2010
Date of granting the first certificate: 10. 06. 2004



Marie Šebestová
Marie Šebestová
Manager of CQS



CQS Members*
Elektrotechnický studijní ústav, s.p., Průmyslný technický studijní ústav, s.p., Institut pro testování a certifikaci, s.p., Strojnický studijní ústav, s.p., Technický a studijní ústav stavění Praha, s.p., Technický a studijní ústav stavění Praha, s.p., - střední ústav - ZÚP, Technický studijní ústav, s.p.
* A CQS member list valid at the time of issue of the certificate. Current list is available at www.cqs.cz

ELEKTROTECHNICKÝ ZKUŠEBNÍ ÚSTAV



ELECTROTECHNICAL TESTING INSTITUTE - CZECH REPUBLIC
 ELEKTROTECHNISCHE PRÜFANSTALT - TSCHÉCHISCHE REPUBLIK
 INSTITUT ELECTROTECHNIQUE D'ESSAIS - RÉPUBLIQUE TCHÈQUE
 ЭЛЕКТРОТЕХНИЧЕСКИЙ ИСПЫТАТЕЛЬНЫЙ ИНСТИТУТ - ЧЕШСКАЯ РЕСПУБЛИКА

Pod Lisem 129, 171 02 Praha 8 - Troja

CE - CERTIFICATE
 of full quality assurance system

No.: MED 090049

The Electrotechnical Testing Institute, Notified Body No. 1014, has decided that Quality System applied by

manufacturer **MZ Liberec, a.s.**
U Nisy 362/6, 460 01 Liberec 3, Czech Republic

for design, manufacture and final inspection of medical devices

Medical devices (of categories IIa IIb):

- medical source units in accordance with ČSN EN ISO 11197 and their components (gas outlets, ejectors, gas seals),
- items, attachable to outputs of gas distribution and AGSS systems (gas outlets counterparts, gas dispensers, humidifiers, ejector suction bottles, pressure and vacuum regulators),
- reducing valves, attachable to cylinders, determined for medical gases applications and their accessories.

complies with provisions of Annex 2 section 3 of Governmental Order No. 336/2004 Coll. (Annex II section 3 of the Council Directive 93/42/EEC) incl. amendments.

This decision is based on the results presented in report No. 901161-01 of: 19.05.2009

In accordance with Art. 5 of Governmental Order No. 336/2004 (Art. 17 of Directive 93/42/EEC), incl. amendments the above specified medical device must be labelled CE 1014.

The certified manufacturer is subject to a surveillance audit by the notified body in accordance with section 5 of Annex 2 of Governmental Order No. 336/2004 Coll. (Annex II section 5 of Directive 93/42/EEC) incl. amendments, and validity of the Certificate is subject to regular supervision. The manufacturer must inform the notified body about any intention resulting in significant modification of quality system or scope of included medical products. In the event that the conditions under which the Certificate has been issued are violated, the notified body may suspend the Certificate's validity or cancel the Certificate.

The validity of Certificate is limited to: 28.5.2014

29.5.2009

Prague

Miroslav Sedláček
 Certification and Inspection Manager



Stamp



901161-01



COUNTRY HOSPITAL/CLINIC

ALBANIA	SALUZ HOSPITAL TIRANA
AZERBAIJAN	MTN HOSPITAL BAKU
BELGIUM	MILITARY HOSPITAL REINE ASTRID
	IN NEDER-OVER-HEMBEECK BRUSSELS
BELGIUM	REHABILITATION HOSPITAL VALIDA
	IN BERCHEM-STE-AGATHE BRUSSELS
CAMEROON	HOSPITAL CENTER PANAFRICAIN GSA DOUALA
CZECH REPUBLIC	UNIVERSITY HOSPITAL IN MOTOL PRAGUE
CZECH REPUBLIC	INSTITUTE FOR CLINICAL
	AND EXPERIMENTAL MEDICINE PRAGUE
CZECH REPUBLIC	UNIVERSITY HOSPITAL BRNO
CZECH REPUBLIC	HOSPITAL NA FRANTIŠKU PRAGUE
CZECH REPUBLIC	NA HOMOLCE HOSPITAL PRAGUE
CZECH REPUBLIC	UNIVERSITY HOSPITAL KRÁLOVSKÉ VINOHRADY
	PRAGUE
CZECH REPUBLIC	THOMAYER HOSPITAL PRAGUE
CZECH REPUBLIC	LIBEREC REGIONAL HOSPITAL
CZECH REPUBLIC	HOSPITAL PŘÍBRAM
CZECH REPUBLIC	HOSPITAL CARLSBAD
CZECH REPUBLIC	MASARYK HOSPITAL IN ÚSTÍ NAD LABEM
CZECH REPUBLIC	HOSPITAL JINDŘICHŮV HRADEC
CZECH REPUBLIC	HOSPITAL CHEB
CZECH REPUBLIC	HOSPITAL „PODHORSKÁ“ BRUNTÁL
CZECH REPUBLIC	UNIVERSITY HOSPITAL ST. ANNA BRNO
CZECH REPUBLIC	UNIVERSITY HOSPITAL OSTRAVA
CZECH REPUBLIC	UNIVERSITY HOSPITAL HRADEC KRÁLOVÉ
CZECH REPUBLIC	REGIONAL HOSPITAL MLADÁ BOLESLAV
CZECH REPUBLIC	REGIONAL HOSPITAL KLDADNO
CZECH REPUBLIC	UNIVERSITY HOSPITAL PLZEŇ
FINLAND	HELSINKI UNIVERSITY HOSPITAL
GABON	OWENDO HOSPITAL LIBREVILLE
GEORGIA	SACHKERE MEDICAL CENTER
GERMANY	HOSPITAL FRANKFURT AM MAIN
HUNGARY	HOSPITAL DEBRECEN
IRELAND	CORK UNIVERSITY HOSPITAL
ITALY	EUROPEAN HOSPITAL ROMA
ITALY	POLICLINICO PORTUENSE ROMA
ITALY	OSPEDALE SAN RAFAELE DI PISANA (ROMA)
KAZAKHSTAN	PRENATAL CENTRUM ALMATY
KAZAKHSTAN	PRENATAL CENTRE ALMATY
KAZAKHSTAN	EMERGENCY HOSPITAL ALMATY
KAZAKHSTAN	CHILDREN HOSPITAL ALMATY

COUNTRY HOSPITAL/CLINIC

KAZAKHSTAN	CARDIOLOGIC CENTRE KARAGANDY
KAZAKHSTAN	PRENATAL CENTRE CHIMKENT
LEBANON	RIZK HOSPITAL BEIRUT
LIBYA	JAMIL HOSPITAL
LITHUANIA	HOSPITAL TRAKAJ CITY
LITHUANIA	REGIONAL CLINIC KLAJPEDA
LITHUANIA	FAMILY CLINIC SHAULIAJ
LITHUANIA	CITY HOSPITAL SHILUJTE
LITHUANIA	CITY HOSPITAL SANTORISHKE
POLAND	HOSPITAL KAMIENNA GORA
POLAND	HOSPITAL OIOM-PULTUSK
POLAND	HOSPITAL SW.RAFALA KRAKOW
POLAND	HOSPITAL DR.SOKOLOWSKIEGO WALBRZYCH
POLAND	HOSPITAL MIEJSKI BYDGOSZCZ
PORTUGAL	HOSPITAL LISBOA
ROMANIA	INEU TOWN HOSPITAL
ROMANIA	DR.GEORGE TRIFON TOWN HOSPITAL
	NĂSAŪD
ROMANIA	FOISOR HOSPITAL BUCHAREST
ROMANIA	ST.STEFAN HOSPITAL BUCHAREST
ROMANIA	COUNTY EMERGENCY HOSPITAL TIMIȘOARA
ROMANIA	VICTOR GOMOIU HOSPITAL BUCHAREST
RUSSIA	MATERNAL HOSPITAL OMSK
RUSSIA	MATERNAL HOSPITAL SALAVAT
RUSSIA	MATERNAL HOSPITAL BELORECK
RUSSIA	REGIONAL HOSPITAL OMSK
RUSSIA	REGIONAL HOSPITAL ARCHANGELSK
RUSSIA	REGIONAL HOSPITAL STAVROPOL
RUSSIA	REGIONAL CLINIC HOSPITAL EKATERINBURG
RUSSIA	CITY HOSPITAL NOJABRSK
RUSSIA	MEDICAL CENTER ULAN-UDE
RUSSIA	RUSSIAN FINNISH CLINIC SCANDINAVIA
	ST.PETERSBURG
SAUDI ARABIA	ZAHRAN AL-JANOUB HOSPITAL RIYADH
SUDAN	HOSPITAL MADANI
SUDAN	SOBA UNIVERSITY HOSPITAL KHARTOUM
SYRIA	DR.SHAMI HOSPITAL DAMASCUS
THE NETHERLANDS	AZM MAASTRICHT
THE NETHERLANDS	MAXIMA MEDISCH CENTRUM VELDHOVEN
UZBEKISTAN	REPUBLICAN SPECIALIZED CENTER OF SURGERY
	TASHKENT
YEMEN	IBN SINA HOSPITAL AL MUKALLA







mz Liberec, a.s.

Czech Republic
Phone: +420 488 040 375
Fax: +420 488 040 326
E-mail: export@mzliberec.cz
www.mzliberec.cz

Copyright © MZ Liberec, a.s., 2013



EUROPEAN UNION
EUROPEAN REGIONAL DEVELOPMENT FUND
INVESTMENT IN YOUR FUTURE

PMH design